

SEAN A. STANTON  
CHAIRMAN

DEBORAH PHILLIPS  
ALANA CHERNILA  
STEPHEN C. BANNON  
ANDREW D. BLECHMAN



Town Hall, 334 Main Street  
Great Barrington, MA 01230

Telephone: (413) 528-1619 x2  
Fax: (413) 528-2290  
website: www.townofgb.org

## TOWN OF GREAT BARRINGTON MASSACHUSETTS

BOARD OF SELECTMEN

SPECIAL MEETING OF THE BOARD OF SELECTMEN

MONDAY, MAY 6, 2013

TOWN HALL, 334 MAIN STREET

ORDER OF AGENDA

**5:00 PM - PUBLIC SESSION – BOARD ROOM**

**I. CALL TO ORDER.**

**II. SWEARING IN OF NEW TOWN MANAGER/JENNIFER TABAKIN.**

**III. APPROVAL OF MINUTES:**

SEPTEMBER 10, 2012 EXECUTIVE SESSION MEETING  
APRIL 29, 2013 SPECIAL MEETING

**IV. BERKSHIRE INTERNATIONAL FILM FESTIVAL (BIFF) BANNERS/FLAGS REQUEST.  
(DISCUSSION/VOTE)**

**V. BRPC/NAT KARNS - BERKSHIRE COUNTY REST OF RIVER LETTER TO DEPARTMENT  
OF ENVIRONMENTAL PROTECTION (DEP). (DISCUSSION/VOTE)**

**VI. ADJOURNMENT.**

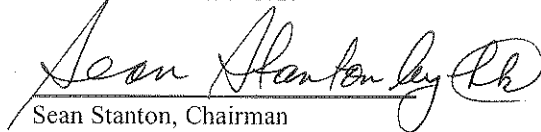
  
Sean Stanton, Chairman

**THIS MEETING MAY BE RECORDED BY MEMBERS OF THE MEDIA.**

**THE LISTING OF AGENDA ITEMS ARE THOSE REASONABLY ANTICIPATED BY THE  
CHAIR WHICH MAY BE DISCUSSED AT THE MEETING. NOT ALL ITEMS LISTED MAY IN  
FACT BE DISCUSSED AND OTHER ITEMS NOT LISTED MAY ALSO BE BROUGHT UP FOR  
DISCUSSION TO THE EXTENT PERMITTED BY LAW.**



**RECEIVED**  
APR 18 2013  
BY: \_\_\_\_\_

TOWN OF GREAT BARRINGTON  
MASSACHUSETTS

OFFICE OF THE INSPECTOR OF BUILDINGS  
APPLICATION FOR A SIGN PERMIT

**NO SIGN IS TO BE ERRECTED OR ALTERED UNTIL A PERMIT IS GRANTED**

The undersigned hereby apply/applies for a sign permit to erect or alter/amend a sign in accordance with the provisions relating hereto.

Application Date: 4/15/2013

Application Made By: Berkshire International film festival

Applicant's Address: 40 railroad street, Suite #5

City, State, Zip: Great Barrington, MA 01230

Telephone Number: 413-528-8030

Property Owner's Name: \_\_\_\_\_

Property Owner's Address \_\_\_\_\_

Signature of property owner indicating consent \_\_\_\_\_

Date: \_\_\_\_\_

Location where sign permit is to be used: 1) corner of main and Pleasant st. to 334 MAIN ST. OF TOWN HALL

Sign District \_\_\_\_\_

2) - 11 railroad st. to 47 railroad's

**Type of Sign**

\_\_\_\_\_ Free Standing

\_\_\_\_\_ Wall-Mounted (flat on wall)

\_\_\_\_\_ Shingle (Projecting)

\_\_\_\_\_ Sandwich Board Sign

\_\_\_\_\_ Double-Sided

\_\_\_\_\_ Permanent Sign

X \_\_\_\_\_ Temporary Sign

12 signs total

Total Area of Requested Sign: \_\_\_\_\_ Sq. Ft. Height: 24" Width: 48"

If sign is to be wall mounted, give total Area of Wall Façade: \_\_\_\_\_ Sq. Ft.

Type of Illumination (if applicable, check one)

\_\_\_\_\_ Internal

\_\_\_\_\_ External

None

\_\_\_\_\_ Other - Please specify \_\_\_\_\_

Setbacks – footage from sign to edge of roadway \_\_\_\_\_ Street line: \_\_\_\_\_

Height From Bottom of Sign to Grade \_\_\_\_\_

Facing property from road: Side property line (Left) \_\_\_\_\_ (Right Side) \_\_\_\_\_

**HISTORIC DISTRICT COMMISSION/ZONING BOARD OF APPEALS**

Is approval required from?

Historic District Commission:  Yes (Please provide documentation of HDC approval with this application.)  
\_\_\_\_\_ No

Zoning Board of Appeals: \_\_\_\_\_ Yes (Please provide documentation of ZBA approval with this application.)  
\_\_\_\_\_ No

\* If approval is required by ZBA and or HDC then such approval MUST be obtained prior to issuance of a Sign Permit\*

I hereby certify that the dimensions and other information on the Plans are correct and that all applicable provisions of the Statutes, Regulations and By-laws will be complied with. The above is subscribed to and executed by me under the penalties of perjury in accordance with Section 1-A of Chapter 268 of the General Laws.

Applicant's Signature \_\_\_\_\_

Date: \_\_\_\_\_

**ATTACH A PHOTO OR SKETCH INDICATING THE COLORS AND MEASUREMENTS OF THE PROPOSED SIGN OR SIGNS**



# CERTIFICATE OF LIABILITY INSURANCE

DATE (MM/DD/YYYY)

3/22/2013

THIS CERTIFICATE IS ISSUED AS A MATTER OF INFORMATION ONLY AND CONFERS NO RIGHTS UPON THE CERTIFICATE HOLDER. THIS CERTIFICATE DOES NOT AFFIRMATIVELY OR NEGATIVELY AMEND, EXTEND OR ALTER THE COVERAGE AFFORDED BY THE POLICIES BELOW. THIS CERTIFICATE OF INSURANCE DOES NOT CONSTITUTE A CONTRACT BETWEEN THE ISSUING INSURER(S), AUTHORIZED REPRESENTATIVE OR PRODUCER, AND THE CERTIFICATE HOLDER.

**IMPORTANT:** If the certificate holder is an **ADDITIONAL INSURED**, the policy(ies) must be endorsed. If **SUBROGATION IS WAIVED**, subject to the terms and conditions of the policy, certain policies may require an endorsement. A statement on this certificate does not confer rights to the certificate holder in lieu of such endorsement(s).

<b>PRODUCER</b> <b>THE ROWLEY AGENCY INC.</b> 139 Loudon Road P.O. Box 511 Concord NH 03302-0511	<b>CONTACT NAME:</b> Donna Bickford <b>PHONE (A/C No. Ext):</b> (603) 224-2562 <b>FAX (A/C No):</b> (603) 224-8012 <b>E-MAIL ADDRESS:</b> dbickford@rowleyagency.com	
	<b>INSURER(S) AFFORDING COVERAGE</b>	
<b>INSURED</b> <b>GVH Studio, Inc.</b> 160 Benmont Avenue, Ste #32 Bennington VT 05201	<b>INSURER A:</b> Travelers Cas Ins Co of Amer	
	<b>INSURER B:</b> Travelers Indemnity Co of CT	
	<b>INSURER C:</b>	
	<b>INSURER D:</b>	
	<b>INSURER E:</b>	
<b>INSURER F:</b>		<b>NAIC #</b> 001110

**COVERAGES****CERTIFICATE NUMBER:****REVISION NUMBER:**

THIS IS TO CERTIFY THAT THE POLICIES OF INSURANCE LISTED BELOW HAVE BEEN ISSUED TO THE INSURED NAMED ABOVE FOR THE POLICY PERIOD INDICATED. NOTWITHSTANDING ANY REQUIREMENT, TERM OR CONDITION OF ANY CONTRACT OR OTHER DOCUMENT WITH RESPECT TO WHICH THIS CERTIFICATE MAY BE ISSUED OR MAY PERTAIN, THE INSURANCE AFFORDED BY THE POLICIES DESCRIBED HEREIN IS SUBJECT TO ALL THE TERMS, EXCLUSIONS AND CONDITIONS OF SUCH POLICIES. LIMITS SHOWN MAY HAVE BEEN REDUCED BY PAID CLAIMS.

INSR LTR	TYPE OF INSURANCE	ADDL SUBR INSR WVD	POLICY NUMBER	POLICY EFF (MM/DD/YYYY)	POLICY EXP (MM/DD/YYYY)	LIMITS
A	GENERAL LIABILITY					EACH OCCURRENCE \$ 1,000,000
	<input checked="" type="checkbox"/> COMMERCIAL GENERAL LIABILITY					DAMAGE TO RENTED PREMISES (Ea occurrence) \$ 300,000
	<input type="checkbox"/> CLAIMS-MADE <input checked="" type="checkbox"/> OCCUR		I6803227M255ACV12	5/1/2012	5/1/2013	MED EXP (Any one person) \$ 5,000
						PERSONAL & ADV INJURY \$ 1,000,000
						GENERAL AGGREGATE \$ 2,000,000
	GEN'L AGGREGATE LIMIT APPLIES PER:					PRODUCTS - COMP/OP AGG \$ 2,000,000
	<input type="checkbox"/> POLICY <input type="checkbox"/> PRO-JECT <input type="checkbox"/> LOC					\$
	AUTOMOBILE LIABILITY					COMBINED SINGLE LIMIT (Ea accident) \$
	<input type="checkbox"/> ANY AUTO					BODILY INJURY (Per person) \$
	<input type="checkbox"/> ALL OWNED AUTOS					BODILY INJURY (Per accident) \$
	<input type="checkbox"/> HIRED AUTOS					PROPERTY DAMAGE (Per accident) \$
	<input type="checkbox"/> SCHEDULED AUTOS					\$
	<input type="checkbox"/> NON-OWNED AUTOS					\$
	UMBRELLA LIAB					EACH OCCURRENCE \$
	<input type="checkbox"/> EXCESS LIAB					AGGREGATE \$
	<input type="checkbox"/> OCCUR					\$
	<input type="checkbox"/> CLAIMS-MADE					\$
	DED					\$
	RETENTION \$					\$
B	WORKERS COMPENSATION AND EMPLOYERS' LIABILITY					<input checked="" type="checkbox"/> WC STATU-TORY LIMITS
	ANY PROPRIETOR/PARTNER/EXECUTIVE OFFICER/MEMBER EXCLUDED? (Mandatory in NH)	Y/N	N/A			OTH-ER
	If yes, describe under DESCRIPTION OF OPERATIONS below		IEUB3227M47612	6/30/2012	6/30/2013	E.L. EACH ACCIDENT \$ 100,000
						E.L. DISEASE - EA EMPLOYEE \$ 100,000
						E.L. DISEASE - POLICY LIMIT \$ 500,000

DESCRIPTION OF OPERATIONS / LOCATIONS / VEHICLES (Attach ACORD 101, Additional Remarks Schedule, if more space is required)  
 Covering operations of the insured during the policy period.

**CERTIFICATE HOLDER****CANCELLATION**

(413) 528-8030

Berkshire International Film Festival  
 Attn: Lauren Ferin  
 PO Box 237  
 Great Barrington, MA 01230

SHOULD ANY OF THE ABOVE DESCRIBED POLICIES BE CANCELLED BEFORE THE EXPIRATION DATE THEREOF, NOTICE WILL BE DELIVERED IN ACCORDANCE WITH THE POLICY PROVISIONS.

AUTHORIZED REPRESENTATIVE

Donna Bickford/DTB

**GVH Studio**  
INCORPORATED  
Graphic Solutions

40 Pageant St. Bennington, VT 05201 • 802-379-1135 [greg@gvhstudio.com](mailto:greg@gvhstudio.com)

March 25, 2013

Kelley Vickery  
Berkshire International Film Festival  
Great Barrington, MA

Dear Kelley,

In response to your structural questions regarding pole banners, we have banners that hang in Lee that were done for Jacobs Pillow using our brackets. Williamstown uses our banners and hardware as well. I can provide a pdf of the bracket instructions so they can review the process. The fiberglass rods bend in the wind to allow the pressure to slide off of the banner. The banners are double thick 13 oz reinforced scrim vinyl. The pole pockets are double stitched with nylon thread. All of these components are fabricated with the specific end use in mind. This is why I am hesitant to endorse the existing brackets in Great Barrington. They are rigid steel brackets that do not provide any escape for wind. If the wind is strong enough, that system has to fail. With the wind release of the flexing rods, banners have withstood 100 mph winds in tests.

If you have any further questions, please feel free to contact me. Many thanks.



Sincerely,

Greg Van Houten  
President

MG\_1847

Lauren Ferin <lauren@biffma.org>  
To: Lauren Ferin <lauren@biffma.org>

Tue, Mar 13, 2012 at 11:47 AM

----- Forwarded message -----

From: lauren ferin <lferin@gmail.com>  
Date: Thu, Mar 31, 2011 at 8:46 AM  
Subject: IMG\_1847  
To: lauren@biffma.org



IMG\_1847

24"x48" TWO SIDED BANNERS  
COLORS ARE PALE BLUE,  
LIME GREEN,  
FUSCHIA PINK.

Lauren Ferin  
Executive Assistant

Berkshire International Film Festival  
P.O. Box 237  
Great Barrington, MA 01230  
413.528.8030  
www.biffma.org

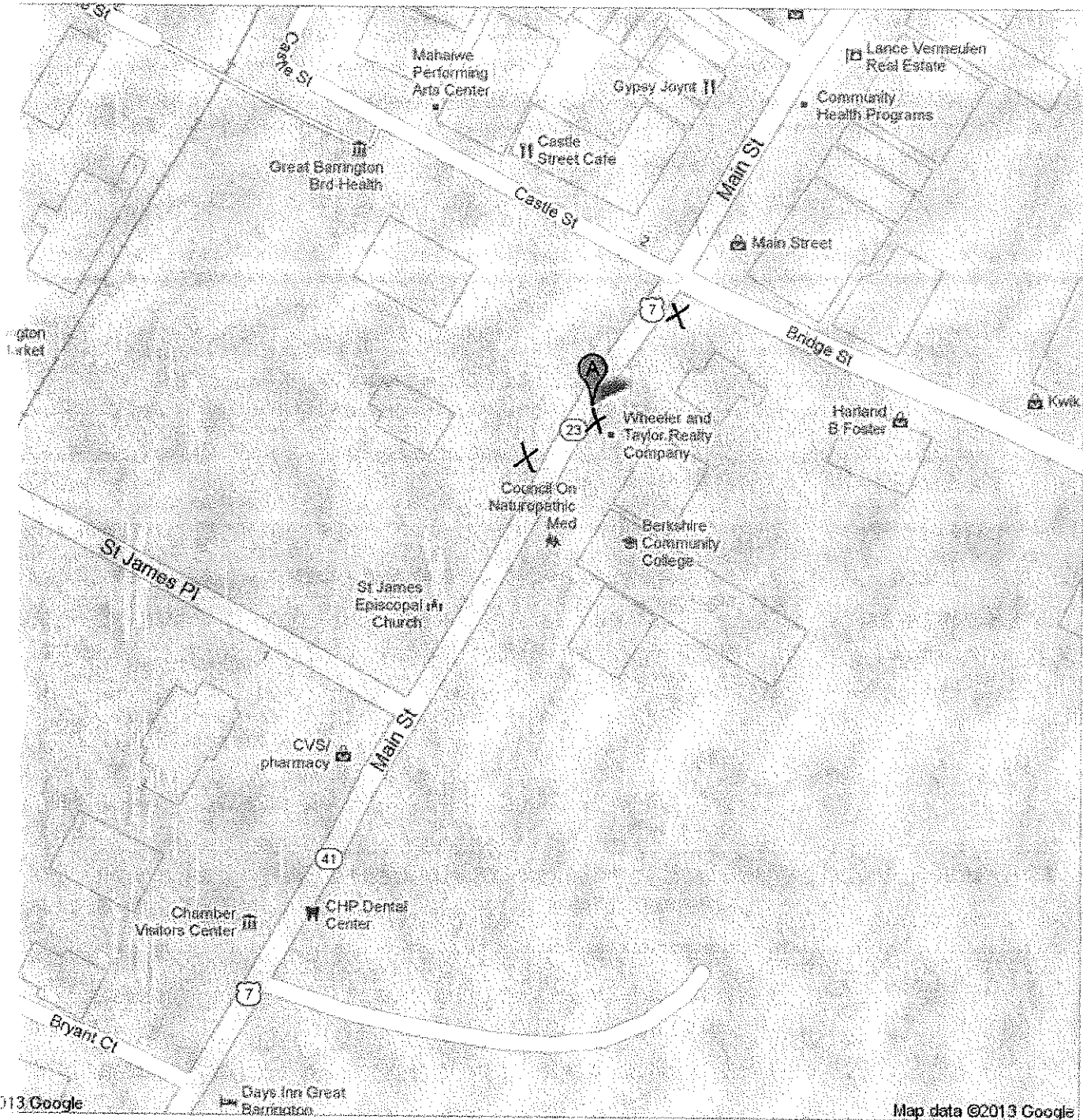

Temporary Display flags at following locations:

- corner of main street and Bridge St. in front of Berkshire Co-op Bank (325 MAIN)
- IN FRONT OF WHEELER & TAYLOR (333 MAIN)
- IN FRONT OF TOWN HALL (334 MAIN)

# BANNER UP!

## "WindSaver" Bracket System

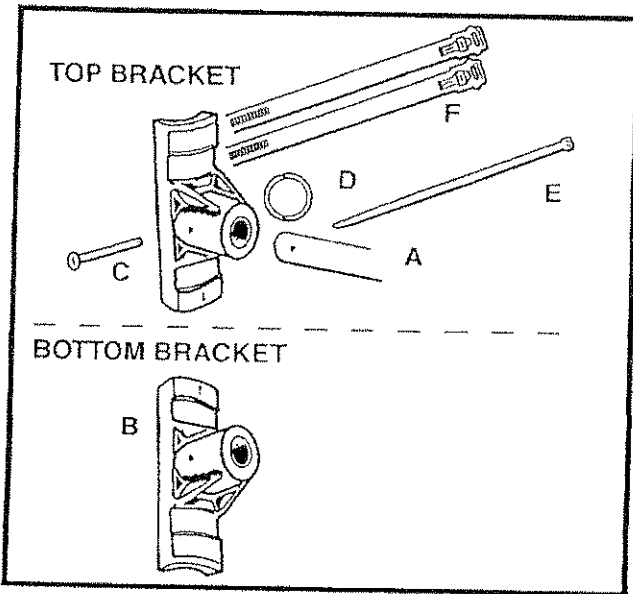

### ASSEMBLY INSTRUCTIONS

- 1) Place fiberglass reinforced rod (a) firmly into the aluminum bracket base (b). Twist until holes line up.
- 2) Insert clevis pin (c) through holes.  
*NOTE: The hole in rod & bracket must line up exactly and may be tight. Tap clevis pin with mallet/hammer through hole if needed.*
- 3) Thread kick-out ring (d) through hole in clevis pin to keep all pieces together.
- 4) Place top bracket/rod assembly at desired height on pole - Arrow on aluminum bracket must be facing (down) towards the banner. Using 3 clamps (f) secure top bracket to pole.  
*NOTE: You must use screwdriver to achieve correct tensioning.*
- 5) Measure down the pole to desired banner length and place bottom bracket/rod assembly to pole. Secure bracket assembly to pole using 3 clamps (f), same as in step 4. *NOTE: Arrow on aluminum bracket must be facing towards the banner or banner will not fit properly. TIP!! After installing top bracket you can slide banner onto top bracket and let fall to determine where the bottom bracket will be placed on the light pole.*
- 6) Slide the banner pockets over the top/bottom bracket arms and fasten banner to bracket system using furnished cable ties (e).  
*NOTE: Cable ties is attached through the grommet on banner and kick-out ring on bracket - secure tightly, but not to cause wrinkle in banner.*

#### "SINGLE BRACKET SET" INVENTORY LIST

- 2 (a) Fiberglass Rod-30"  
*(can be customized to any length)*
- 2 (b) Aluminum Bracket Bases
- 2 (c) Clevis Pins
- 2 (d) Kick-Out Rings
- 2 (e) Cable Ties
- 6 (f) SS Band Clamp (40")

#### "DOUBLE BRACKET SET" INVENTORY LIST

- 4 (a) Fiberglass Rod-30"  
*(can be customized to any length)*
- 4 (b) Aluminum Bracket Bases
- 4 (c) Clevis Pins
- 4 (d) Kick-Out Rings
- 4 (e) Cable Ties
- 6 (f) SS Band Clamp (40")

### RECOMMENDED INSTALLATION TOOLS

- Slotted Screw Driver\*
- Hammer or Mallet
- Extension Ladder or Boom Truck

#### •Installation Note:

All clamps should be tightened with only a screwdriver. Powered tools will break the clamps

### DOUBLE BRACKET SYSTEM INSTALLATION

If you are installing double brackets follow all of the steps above except use (2) Windsaver Bracket/Rod assemblies top and bottom - Parallel to each other.

#### NOTE:

You will still use the same amount of clamps (f) to secure double system to pole. For double bracket systems you may find it easier to install brackets first and then assemble fiberglass rods into brackets.

Banner-Up! "WindSaver" Light Pole Bracket System are warranted against manufacturer defect only. Over time the aluminum base will oxidize, this will NOT effect performance of the bracket system. If you are installing on an aluminum pole it will eventually match the sheen. ALWAYS inspect the band clamps when reinstalling bracket system. It is more cost effective to replace at time of reinstallation than when failure occurs.





Address 265 Main St  
Great Barrington, MA 01230

Get Google Maps on your phone  
Text the word "GMAPS" to 466453

TEMPORARY DISPLAY FLAGS AT THE FOLLOWING LOCATIONS :

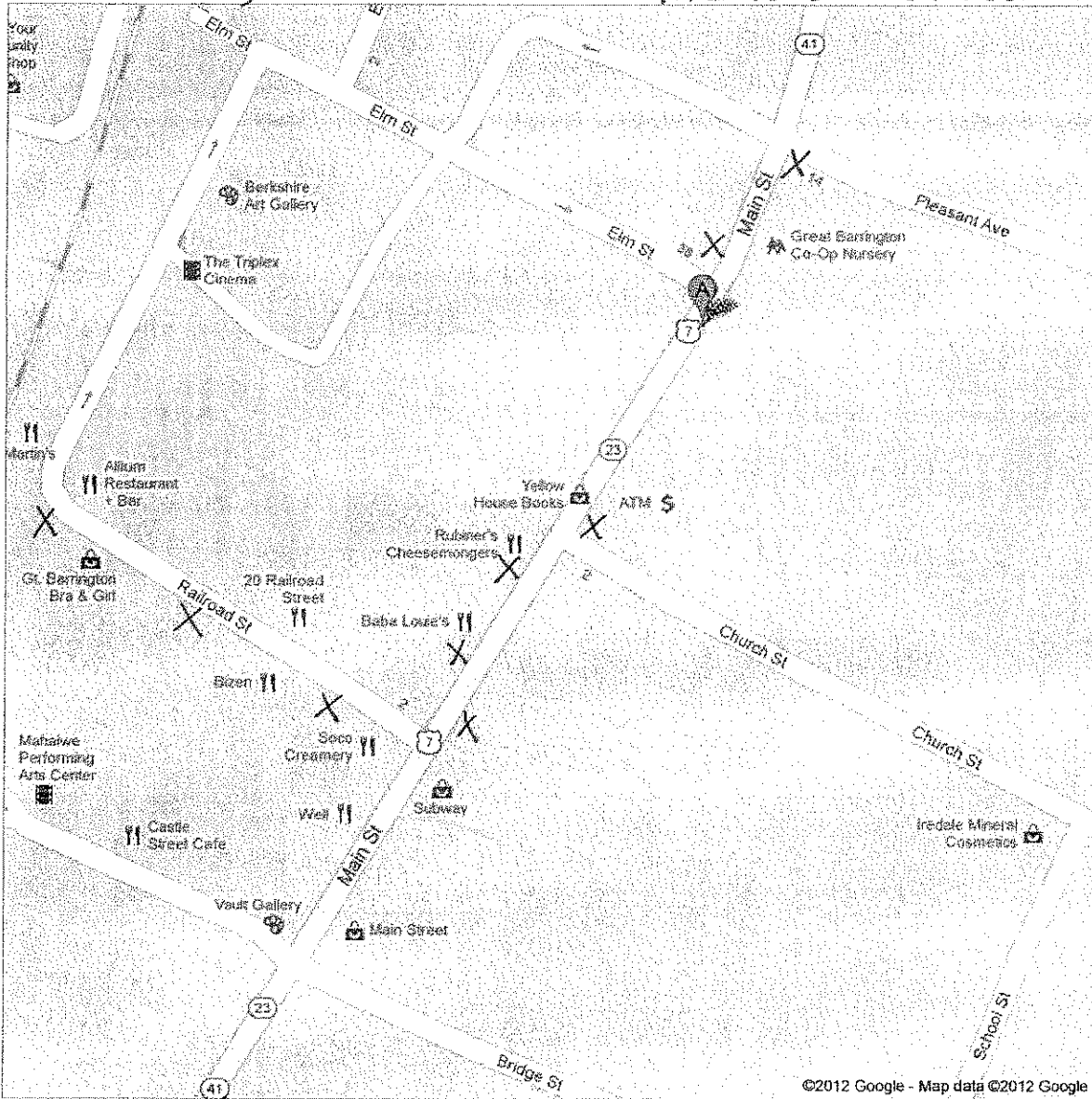

RAILROAD ST. IN FRONT OF IRIS GALLERY  
CHEF SHOP = 3  
VAULT STUDIO

MAIN ST.  
CORNER OF MAIN & PLEASANT ST. = 6  
FRONT OF BERKSHIRE BANK CLOCK SIGN  
FRONT OF SIMS BARBER SHOP @ MAIN AND CHURCH ST'S.  
FRONT OF RUBINER'S  
FRONT OF SIAM SQUARE THAI RESTAURANT  
FRONT OF EVERGREEN FINE AMERICAN CRAFTSHOP

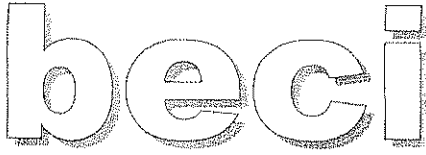

barry engineers and constructors, inc.

176 churchill street, pittsfield, massachusetts 01201

413-443-6591

March 20, 2013

Ed May  
Great Barrington Building Inspector  
Town Hall  
Main Street  
Great Barrington, MA. 01230

Dear Ed:

I have reviewed the Wind Saver Bracket for the support of the proposed 23"x66" flags for an approximate 45 day period this spring for the Berkshire International Film Festival. Based on my review, it is my opinion that these brackets are sufficient as attachments for the fiberglass rods which support the flags and resist the required wind loads. The brackets and flags should be installed per the manufacturer's recommendations. Should you have additional questions or need further information, please contact me.

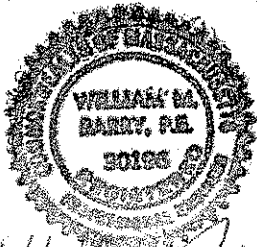

*William M. Barry*  
William M. Barry

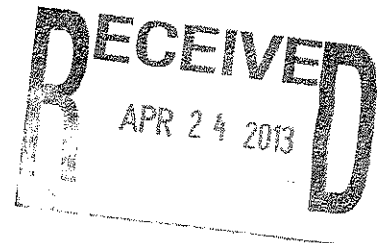

Ms. Lauren Ferin  
Berkshire International Film Festival  
P. O. Box 237  
Great Barrington, MA 01230

April 23, 2013

Dear Ms. Ferin,

The Historic District Commission at its April 18, 2013, meeting voted unanimously to allow the hanging of 12 banners along Main and Railroad Streets for a period of 45 days starting April 26, 2013.

Best wishes for much success with this endeavor, and the Historic District is pleased to be able to offer support for this film festival that is enjoyed by so many in our community.

Sincerely,

James J. Mercer  
Chairman

**V-SIGN:** A sign containing two faces, positioned at an interior angle of less than 30°. Any sign whose two faces are positioned at an interior angle greater than 30° is not permitted.

**WALL SIGN:** A sign painted on or attached directly to the surface of a building wall and extending not more than 10 inches from the face of such wall.

**WINDOW SIGN:** A sign on exterior windowpanes or glass or placed inside an exterior window or door and intended to be visible from the exterior of the premises.

### 146-3. General Requirements.

1. **Abandoned Signs.** Any on-premises sign which advertises a business no longer conducted at the premises, or any off-premises sign which advertises a business no longer conducted at its separate premises, shall be removed by the owner, or if the owner fails to do so, by the Building Inspector, within 120 days of abandonment or cessation of such business.
2. **Color.** No sign, except for posters or temporary signs, shall use any day-glow or fluorescent colors on either its copy or background.
3. **Safe Condition.** All signs shall be maintained in good repair, in good structural condition and in compliance with all building and electrical codes. No sign shall be erected that obstructs any door, window or fire escape or otherwise interferes with the proper functioning of any building. No sign shall constitute a hazard to public safety or health by reason of its location, inadequate maintenance, dilapidation, abandonment, or by causing any obstruction of sight distances for vehicular traffic or interference with pedestrian safety.
4. **Sign Posts.** Sign posts and supports shall not contain lettering and shall be kept plumb and in good condition.
5. **Traffic Sight Lines.** No sign shall be erected that obstructs traffic sight lines for drivers or pedestrians. A freestanding sign shall not be placed within the triangle formed by connecting the intersection of any street lines with the points on each street line 20 feet from such intersection.
6. **Trees and Poles.** No sign shall be permitted on trees, light poles, telephone poles, or street identification signs except such signs as are erected by the Town of Great Barrington or the Commonwealth of Massachusetts for traffic or pedestrian safety purposes.

### 146-4. Types of Signs.

1. **Animated Signs.** Rotating signs, animated signs, rotating beacons, electronic message signs or centers and otherwise moving signs shall be prohibited in all zoning districts.

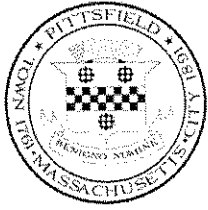

Massachusetts Department of Environmental Protection  
Bureau of Resource Protection – Regulatory Comment Box  
One Winter Street, Fifth Floor  
Boston, MA 02108

RE: Proposed Amendments to Wetland and Waterway Regulations

To Whom It May Concern:

The six Berkshire County Rest of River communities (the City of Pittsfield and Towns of Lenox, Lee, Stockbridge, Great Barrington and Sheffield) wish to strongly comment on the proposed amendments to the Wetland and Waterway Regulations as they may affect the clean-up of PCB's from the Housatonic Rest of River. There are three specific regulation changes which appear to negatively impact our municipalities' and the Commonwealth of Massachusetts' ability to have a reasonable degree of control over some aspects of the clean-up as it may occur. The activity of dredging is a main feature of streamlining efforts within much of the regulatory changes and is a main concern of ours.

1. Ecological Restoration Project. The creation of this type of project may be warranted and beneficial in some cases. However, the proposed definition of Ecological Restoration is too broad and could be interpreted to include hazardous substances or waste. Cleanup activities that are being ordered under federal and/or state statutes, such as CERLA, RCRA and other environmental laws, should be excluded from the Ecological Restoration Project status. This is particularly important for large cleanup projects such as the Housatonic Rest of River. This exclusion is absolutely necessary to prohibit Responsible Parties, such as the General Electric Company (GE), from using this new project category to allow dredging and disposal of dredged materials in environmentally sensitive areas that are currently off limits to them.
2. Ecological Restoration Limited Project. The granting of limited project status for some Ecological Restoration projects, within the General Permit process, limits the ability of the local Conservation Commission to impose reasonable conditions to protect wetland resources within their own boundaries.
3. Dredged Material Disposal. The new regulations allow for the disposal of dredged material within an ACEC if the work is part of Ecological Restoration Project. We oppose any regulatory changes by DEP which will make permitting of dredging, disposal, reuse, and placement of fill within an ACEC easier to accomplish. By designation of an ACEC, the Commonwealth has determined that these are especially important ecological areas and thus should be provided the highest level of environmental review and protection. The proposed changes are in absolute contradiction to that premise.

As the Department of Environmental Protection is well aware, the probable course of action for removing PCBs from the Housatonic Rest of River involves dredging sediment from the river channel, banks and floodplain within the river corridor and dredging of Woods Pond. This section of the Housatonic River is entirely within the Upper Housatonic River Area of Critical Environmental Concern. GE has made no secret of its desire to dispose of all the dredged contaminated material in disposal sites within Berkshire County, including the most probable site at Lane Construction Company's site in Lee, which is within the Upper Housatonic River ACEC.

The convergence is these three specific changes to the wetland and waterways regulations could unwittingly diminish the Commonwealth's ability to oversee and condition PCB cleanup activities within the Rest of River, and it could allow GE to dispose of contaminated sediments within the Upper Housatonic River ACEC. We, the six Berkshire County municipalities of Pittsfield, Lenox, Lee, Stockbridge, Great Barrington and Sheffield, adamantly oppose any wetland /waterway regulations that could allow the disposal of contaminated sediments within an ACEC.

Sincerely,

---

Mayor Daniel Bianchi, City of Pittsfield

---

Lenox Select Board Chair

---

Lee Select Board Chair

---

Stockbridge Select Board Chair

---

Great Barrington Select Board Chair

---

Sheffield Select Board Chair